

hydroo [®]	Product information VDROO3-25	Manufacturer	Hydroo
		Address	
		Contact way	(+34) 972 394 654
		Date	2020/07/31
		Client Name	Electropompa
Project Name		Client Addr.	Moscow
Station Number		Contacts	
		Contact way	

Product No.	VF3-25R 0300 T 2340 5 2 IE3		
Product picture(Note: the picture may not be the same as the actual product.)	Series description		
	<p>VDROO is a new series of vertical multistage centrifugal pumps made by Hydroo. It includes different versions: VF, VX, VN and VD and their corresponding pumps sets with motor and with variable frequency drivers.</p> <p>VDROO range has been designed to meet the highest demanding in pumping installations. It has been designed, engineered, industrialized and finally, is being produced in the main factory of Hydroo in Palol de Revardit, Catalonia-Spain.</p>		

Performance Date

Rated flow(m ³ /h)	3
Rated head(m)	150
Efficiency(%)	58
Rated power(kW)(kW)	2.11
NPSHr(m)	1.4
Impeller Dia(mm)	82
Rate Speed(rpm)	2900
Impeller stage	25
Min. Flow (m ³ /h)	1.2
Max. Flow (m ³ /h)	4.4
Max. Efficiency (%)	58
MEI	0,8
Pump Weight (kg)	57

MATERIAL

Impeller/Diffuser/Casing	AISI 304
Rubber code	E
Inlet & Outlet chamber	ASTM 25B

INSTALLATION

Connection Code	R
Connection type	Threaded Round flange
Max. pressure (bar)	23
Low/High Temperature()	-15 / 120
Pressure rating	PN25-40
Inlet & Outlet Connection s	DN25
Max. Environment temperatur	40

MOTOR

Number of Motor Phases	3~
Protection Class	IP55
Insulation Class	F
Motor Power (kW)	3
Frequency(Hz)	50
Rated speed(rpm)	2900
Rated voltage (V)	230/400
Rated current (A)	9.9/5.7
cos	0.87
Energy efficiency Level	IE3

hydroo [®]	Product information VDROO3-25	Manufacturer	Hydroo
		Address	
		Contact way	(+34) 972 394 654
		Date	2020/07/31
		Client Name	Electropompa
Project Name		Client Addr.	Moscow
Station Number		Contacts	
		Contact way	

Efficiency100%	87.1
Efficiency75%	87.7
Efficiency50%	87.1
Drive end bearing	6306ZZ
Non-drive end bearing	6206ZZ
Motor Weight (kg)	28.5

SEAL

Mechanical Seal	D12 WBE4
-----------------	----------

hydroo [®]	Performance Curve VDROO3-25	Manufacturer	Hydroo
		Address	
		Contact way	(+34) 972 394 654
		Date	2020/07/31
Project Name		Client Name	Electropompa
Station Number		Client Addr.	Moscow
		Contacts	
		Contact way	

Medium Name Temperature °C, Density 1000 kg/m³ Viscosity 1 mm²/s (ISO 9906 2012 Grande 3B)

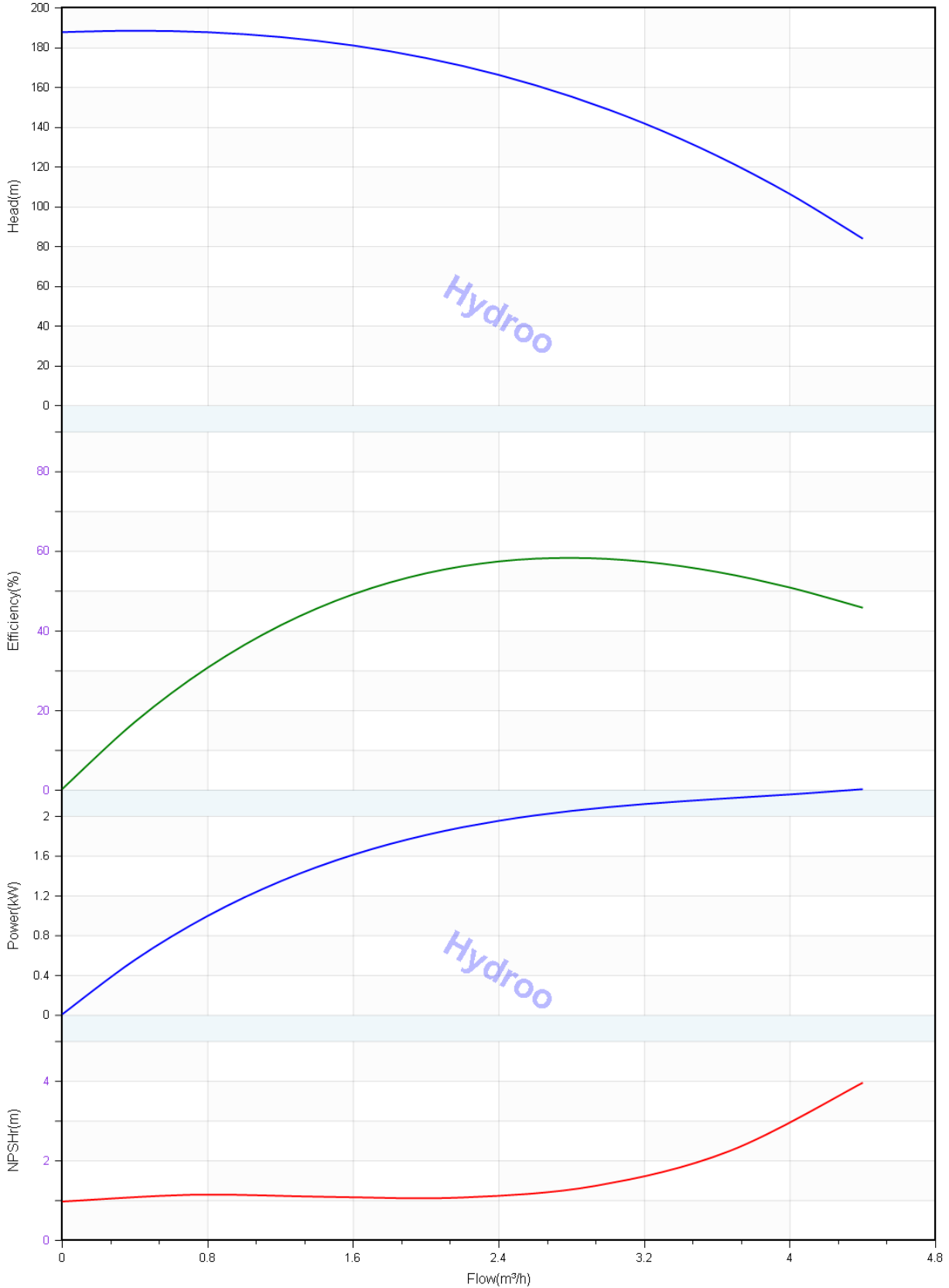

hydroo [®]	Pump technical parameters VDROO3-25	Manufacturer	Hydroo
		Address	
Project Name		Contact way	(+34) 972 394 654
		Date	2020/07/31
Station Number		Client Name	Electropompa
		Client Addr.	Moscow
		Contacts	
		Contact way	

Rated parameters

Pump model	VDROO3-25
Product No.	VF3-25R 0300 T 2340 5 2 IE3
Rated flow(m ³ /h)	3
Rated pressure(m)	150
Rated efficiency(%)	58
Power(kW)	2.11
NPSHr(m)	1.4
Speed(rpm)	2900

Medium

Medium Name	clear water
Working temperature(°C)	20
Medium density(kg/m ³)	1000
Viscosity(mm ² /s)	1

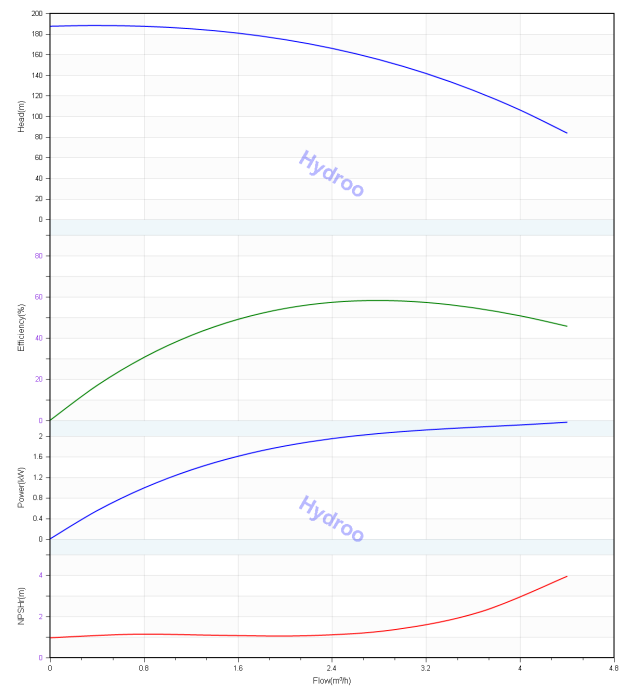

hydroo [®]	Structure picture VDROO3-25	Manufacturer	Hydroo
		Address	
Project Name		Contact way	(+34) 972 394 654
		Date	2020/07/31
Station Number		Client Name	Electropompa
		Client Addr.	Moscow
		Contacts	
		Contact way	

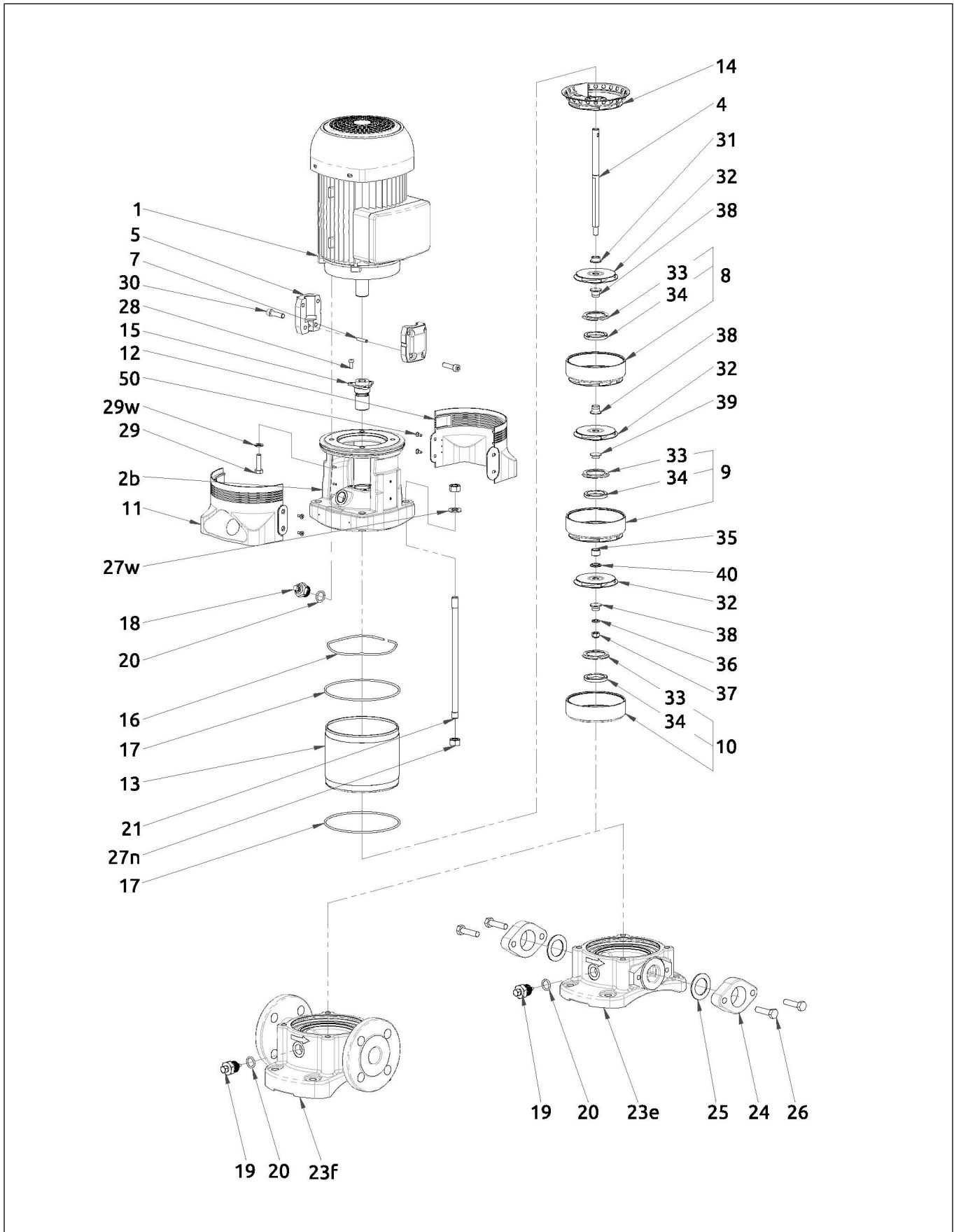

hydroo [®]	Installation drawing VDROO3-25	Manufacturer	Hydroo
		Address	
Project Name		Contact way	(+34) 972 394 654
		Date	2020/07/31
Station Number		Client Name	Electropompa
		Client Addr.	Moscow
		Contacts	
		Contact way	

