

<b>hydroo</b> <sup>®</sup>	<b>Product Information</b> <b>VDROO5-23</b>	Manufacturer	Hydroo
		Address	
		Contact	(+34) 972 394 654
		Date	2022/06/02
<b>Project Name</b>		Client Name	GK Electropompa
		Client Addr.	Russia, Moscow
<b>Item NO</b>		Contacts	
		Contact	7(495)981-92-44(45)

Part NO.	VF5-23R 0400 T 2340 5 2 IE3
----------	-----------------------------

Product Picture	Note
	<p>VDROO is a new series of vertical multistage centrifugal pumps made by Hydroo. It includes different versions: VF, VX, VN and VD and their corresponding pumps sets with motor and with variable frequency drivers.</p> <p>VDROO range has been designed to meet the highest demanding in pumping installations. It has been designed, engineered, industrialized and finally, is being produced in the main factory of Hydroo in Palol de Revardit, Catalonia-Spain.</p>

### Nameplate parameters

flow	5 m <sup>3</sup> /h
head	142 m
speed	2900
number of stages	23

### Performance Data

Min. Flow (m <sup>3</sup> /h)	2.5
Max. Flow (m <sup>3</sup> /h)	8.5
Max. Efficiency (%)	70
MEI	≥ 0,8
Pump Weight (kg)	65

### MATERIAL

Impeller/Diffuser/Casing	AISI 304
Rubber code	E
Inlet & Outlet chamber	ASTM 25B

### INSTALLATION

Connection Code	R
Connection type	Threaded Round flange
Max. pressure (bar)	24
Low/High Temperature (°C)	-15 / 120
Pressure rating	PN25-40
Inlet & Outlet Connection	DN32
Max. Environment temperatu	40

### MOTOR

Number of Motor Phases	3~
Protection Class	IP55
Insulation Class	F
Motor Power (kW)	4
Frequency(Hz)	50
Rated speed(rpm)	2900
Rated voltage (V)	230/400
Rated current (A)	13.0/7.4
cosφ	0.88
Energy efficiency Level	IE3
Efficiency100%	88.1
Efficiency75%	88.5

<b>hydroo</b> <sup>®</sup>	<b>Product Information</b> <b>VDROO5-23</b>	Manufacturer	Hydroo
		Address	
		Contact	(+34) 972 394 654
		Date	2022/06/02
<b>Project Name</b>		Client Name	GK Electropompa
		Client Addr.	Russia, Moscow
<b>Item NO</b>		Contacts	
		Contact	7(495)981-92-44(45)

Efficiency50%	87.9
Drive end bearing	6306ZZ
Non-drive end bearing	6306ZZ
Motor Weight (kg)	35
<b>SEAL</b>	
Mechanical Seal	D12 WBE4

<b>hydroo</b> <sup>®</sup>	<b>Performance Curve</b> <b>VDRO05-23</b>	Manufacturer	Hydroo
		Address	
		Contact	(+34) 972 394 654
		Date	2022/06/02
<b>Project Name</b>		Client Name	GK Electropompa
		Client Addr.	Russia, Moscow
<b>Item NO</b>		Contacts	
		Contact	7(495)981-92-44(45)

The hydraulic performance curve have been tested with Water at °C, density 1000kg/m<sup>3</sup>, and at 1bar atmospheric pressure. GB32162016 Grande 3B

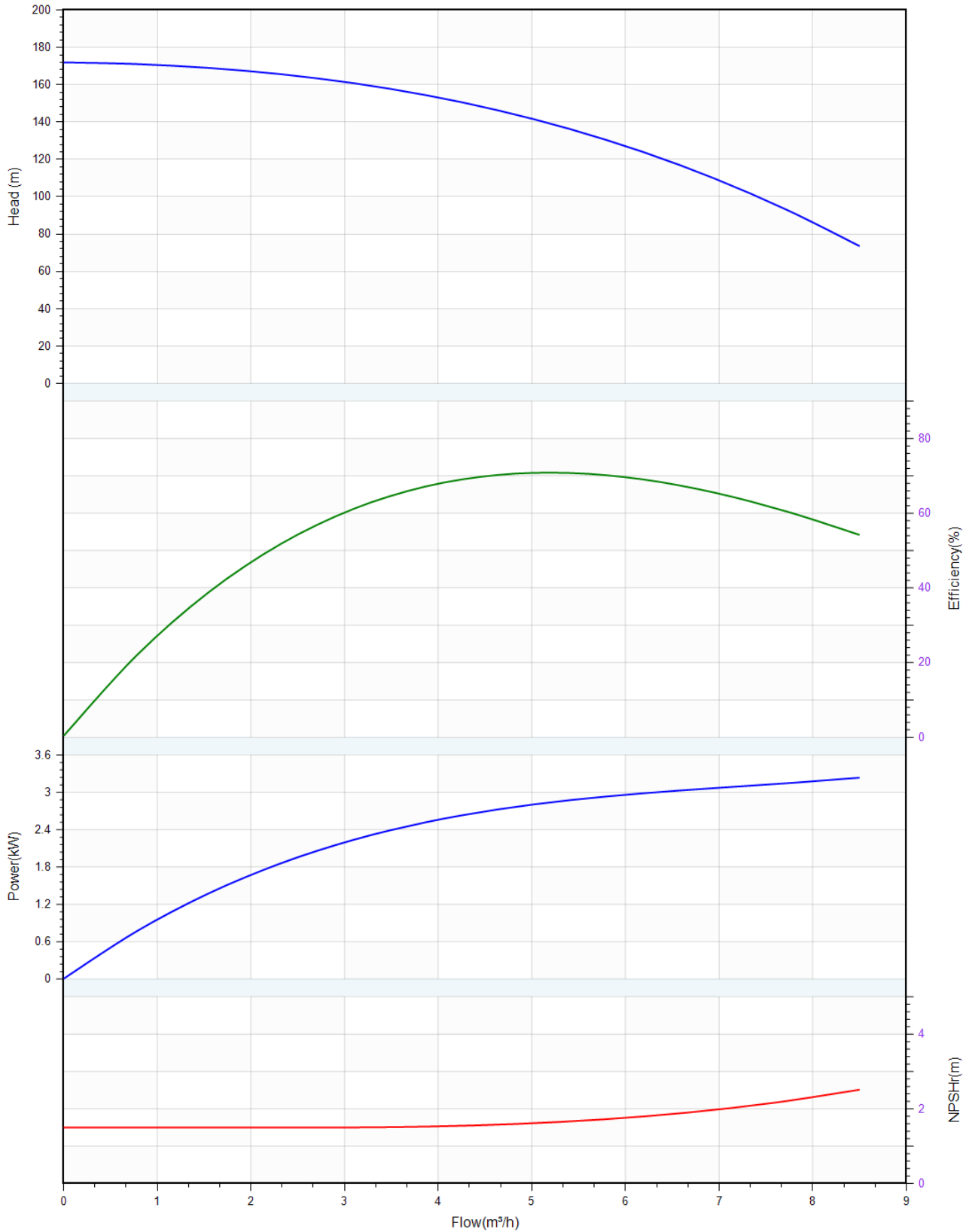

<b>hydroo</b> <sup>®</sup>	<b>Pump Technical Parameters</b> <b>VDRO05-23</b>	Manufacturer	Hydroo
		Address	
		Contact	(+34) 972 394 654
		Date	2022/06/02
<b>Project Name</b>		Client Name	GK Electropompa
		Client Addr.	Russia, Moscow
<b>Item NO</b>		Contacts	
		Contact	7(495)981-92-44(45)

Rated parameters	
Pump model	VDRO05-23
Part NO.	VF5-23R 0400 T 2340 5 2 IE3
Rated flow	5 m <sup>3</sup> /h
Rated head	142 m
Rated efficiency (%)	70
Power (kW)	2.76
NPSHr (m)	1.6
Speed (rpm)	2900
Max impeller diameter (mm)	82
Medium	
Pumped medium	Water
Working temperature (°C)	20
Medium density (kg/m <sup>3</sup> )	1000
Viscosity (mm <sup>2</sup> /s)	1

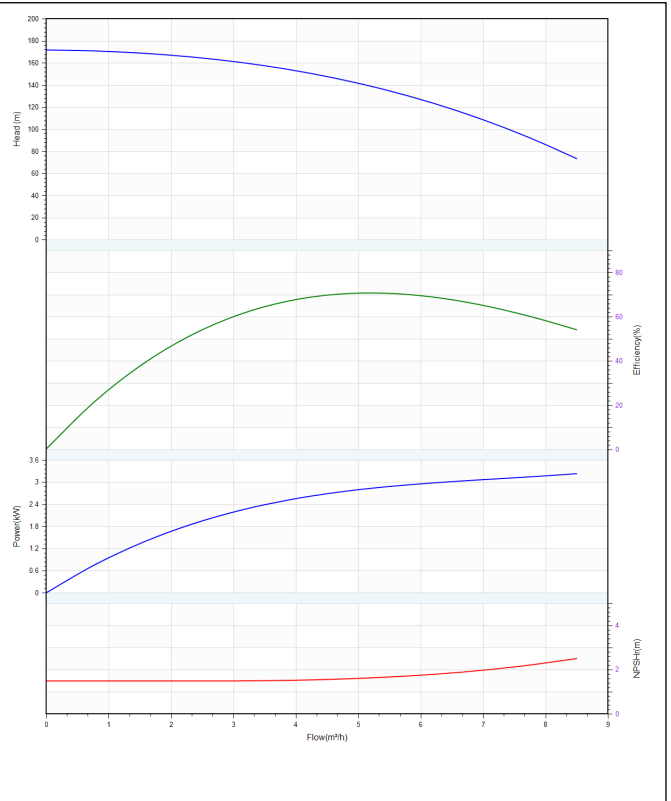

<b>hydroo®</b>	<b>Structure picture</b> <b>VDRO05-23</b>	Manufacturer	Hydroo
		Address	
		Contact	(+34) 972 394 654
		Date	2022/06/02
<b>Project Name</b>		Client Name	GK Electropompa
		Client Addr.	Russia, Moscow
<b>Item NO</b>		Contacts	
		Contact	7(495)981-92-44(45)

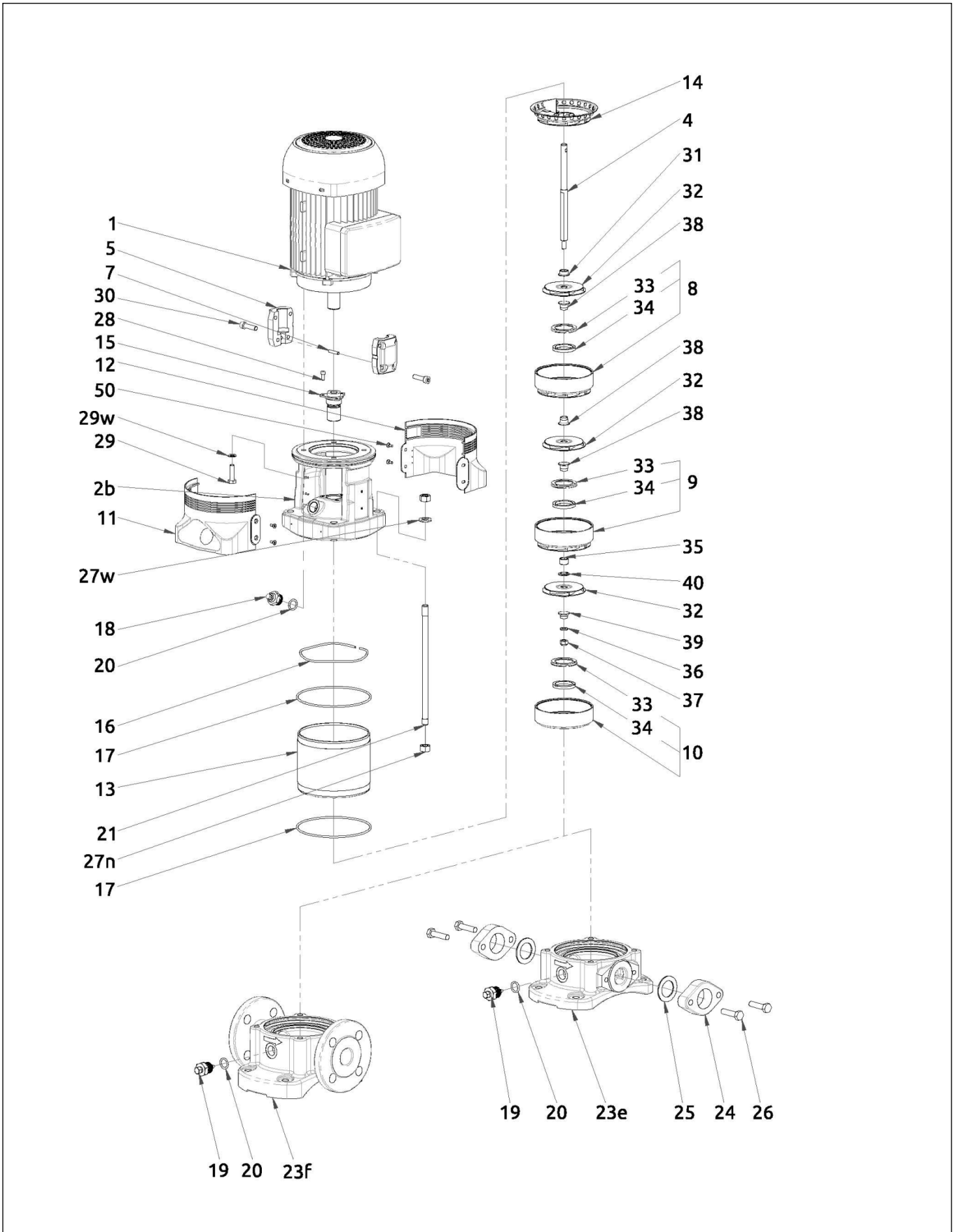

<b>hydroo</b> <sup>®</sup>	<b>Installation picture</b> <b>VDRO05-23</b>	Manufacturer	Hydroo
		Address	
		Contact	(+34) 972 394 654
		Date	2022/06/02
<b>Project Name</b>		Client Name	GK Electropompa
		Client Addr.	Russia, Moscow
<b>Item NO</b>		Contacts	
		Contact	7(495)981-92-44(45)

